

# TL100AB18-001 A

## HIGH POWER ALN TERMINATION

SPECIFICATIONS		FILE: TERMOUT
POWER MAX (WATTS):	100 CW	
RESISTANCE	50 OHMS (±5%)	
FREQUENCY	VSWR	
DC - 3000 MHz	1.1 : 1	

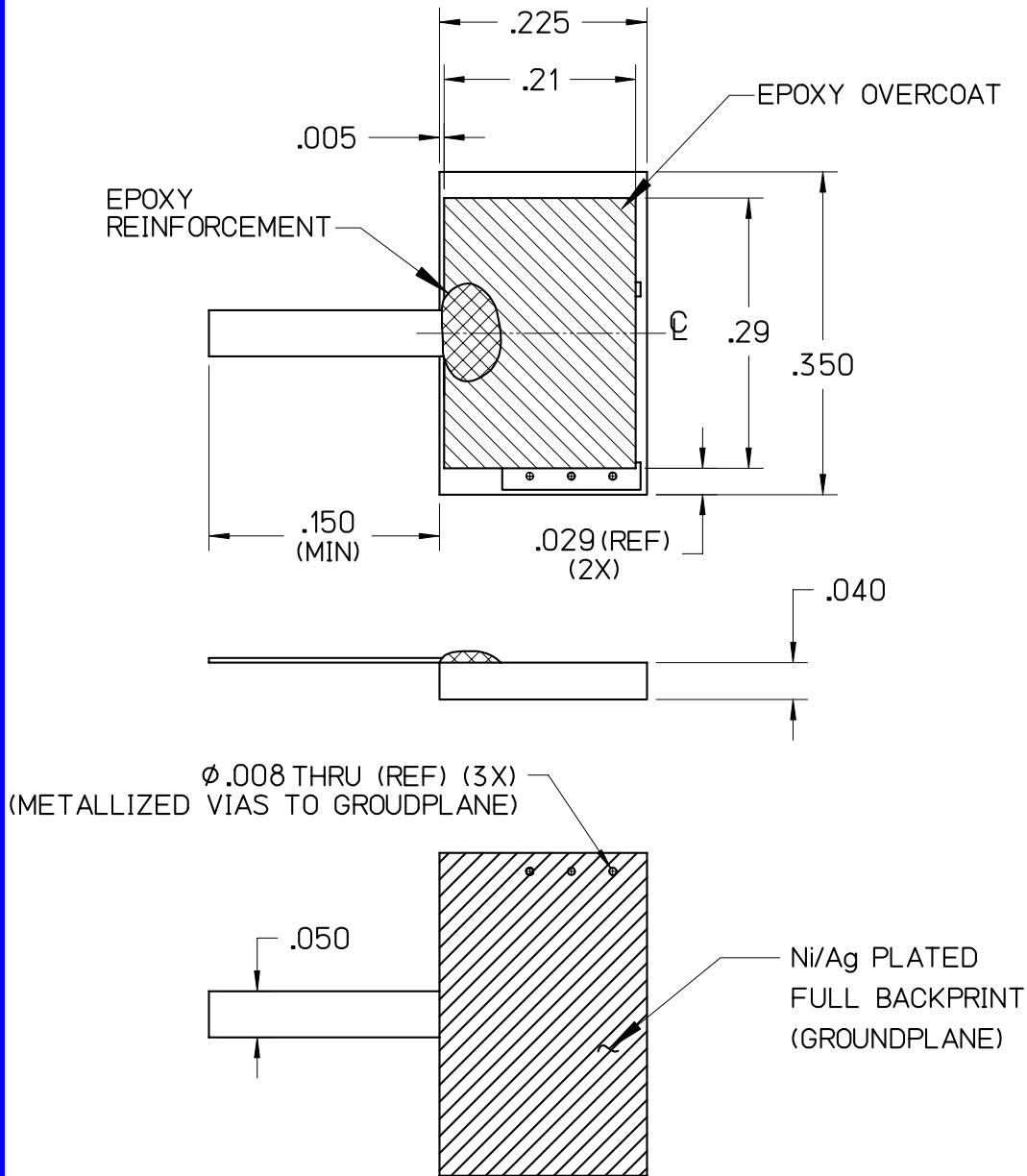

A	04/17/09	MAI	-	-	000760
LEVEL	DATE	DRN.	CHK.	APP.	ECN
REVISIONS					
DRN.	MAI	CHK.	MAI	APP.	MAI
DATE	04/17/09	DATE	04/17/09	DATE	04/17/09
					SCALE
					6" = 1"
					.XX ± .015
					.XXX ± .010



**JOHANSON MANUFACTURING CORPORATION**  
 ROCKAWAY VALLEY ROAD, BOONTON, N.J. 07005 (973)334-2676 FAX (973)334-2954  
 ELECTRONIC ACCURACY THROUGH MECHANICAL PRECISION